

Coinceurs doubles

Pour montage spécifique

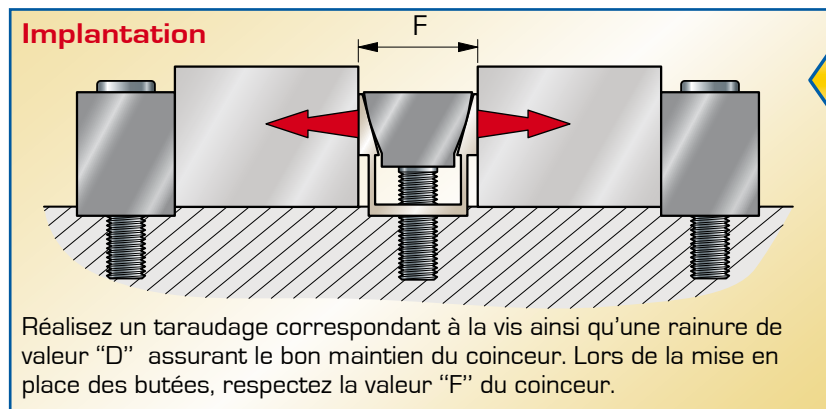

- Bridage simultané de 2 pièces
- Système compact
- Démontage très rapide

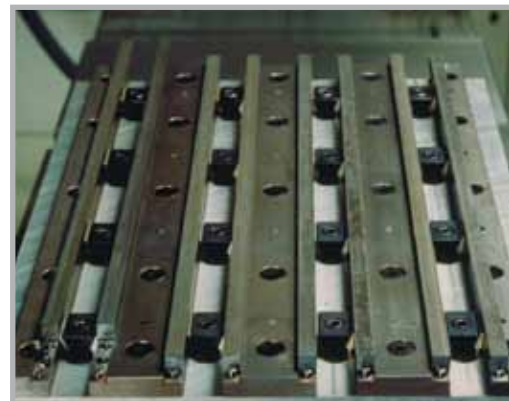

2,7 Tonnes
27000 Newton

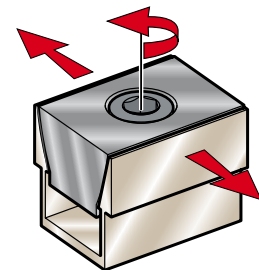

La vis de serrage assure le bridage de 2 pièces simultanément en répartissant uniformément la force de bridage.



Coinqueur "uniforce"

Vis	A	B	B 1	C	D	E	F	F maxi	Puissance	Qté.	Réf.
M 2	6.1	6.9	6.4	8.1	5.3	3.6	6.4	6.7	900 N.	6	MB-100
M 2.5	9.1	9.7	9.5	11.9	7.9	4.7	9.5	10.0	1350 N.	6	MB-102
M 4	12.3	14.5	12.7	15.9	10.4	5.6	12.7	13.2	2200 N.	8	MB-104
M 6	18.6	19.0	19.05	23.8	16.1	9.5	19	20.3	6800 N.	6	MB-106
M 8	24.8	25.9	25.4	31.7	20.8	12.7	25.4	26.9	9000 N.	4	MB-108
M 12	37.3	38.6	38.1	47.6	30.8	19.0	38.1	39.9	15800 N.	2	MB-112
M 16	49.75	51.7	50.8	63.5	41.25	25.4	50.8	53.0	27000 N.	2	MB-116

Profilé longueur 508 mm aluminium acier

F	Réf.	Réf.
6.4	MB-820	MB-821
9.5	MB-822	MB-823
12.7	MB-824	MB-825
19	MB-826	MB-827
25.4	MB-828	MB-829
38.1	MB-830	MB-831
50.8	MB-832	MB-833

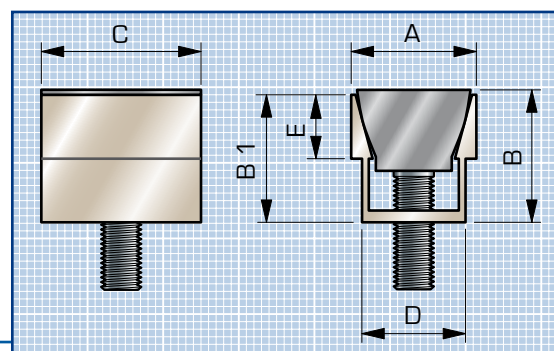

HORIZONTAL 3



Profilé identique aux coinqueurs uniforces